

THE  AWNING CO

 MADE IN BRITAIN

FRONTIER OPERATING INSTRUCTIONS





**SPACE AND
SIMPLICITY
FOR ALL
YOUR NEEDS**

| CONTENTS

PAGE 4	WARNING
PAGE 5	PRE-ASSEMBLY CHECK
PAGE 6	1. WIND OUT THE ROOF SHEET
PAGE 6	2. FIT CORNERS POST
PAGE 7	3. FIT SIDE ROOF RAILS
PAGE 8	4. FIT TORSION BAR
PAGE 8	5. TENSION ROOF
PAGE 8	6. SECURE AWNING DOWN
PAGE 9	7. FIT SHEETS
PAGE 9	8. FIT TERRACE SHEET AND RAIL - OPTIONAL
PAGE 10	9. FIT BASEFRAME - OPTIONAL
PAGE 10	10. DISMANTLING
PAGE 11	11. RETRACTING THE ROOF

WARNING

Assembly of this awning will require some working at height and manual handling. Injury may result if instructions are ignored. It is the customer's responsibility to see that the awning is properly assembled, installed and taken care of. Failure to follow the instructions in this manual could result in bodily injury and/or property damage.

FOR YOUR SAFETY

- Ensure adequate training in the use of ladders/steps
- Ensure all ladders/steps had been inspected before use, are in good repair and suitable for the operation being carried out
- Ensure persons carrying out this operation have been trained in manual handling and working at heights
- No persons with previous medical history e.g. back or limb injuries that may be affected by the manual handling involved should be allowed to carry out this operation
- Ensure all PPE is worn as appropriate, including hard hat, safety shoes and gloves

PRECAUTIONS

- Ensure the ground is level and that there is no risk of sinkage. (Vehicle wheels may need to be mounted on wood if the ground is loose)
- Ensure vehicle wheels are chocked to prevent movement
- Always take precautions to hold down whilst the awning is being wound out
- Ensure the awning can be anchored securely in challenging weather conditions. Always secure down the awning using the pegs provided. If pegs cannot be used rawlbolt or fix down to an immovable object using straps
- Never wind the awning out in bad weather

**PLEASE READ THE INSTRUCTIONS
CAREFULLY BEFORE ASSEMBLY, RETAIN
THIS MANUAL FOR FUTURE REFERENCE.**

PRE-ASSEMBLY CHECK

The first time you assemble your awning you may want to layout the poles to familiarise yourself with the contents. Check that all the parts are present and fixings are undamaged before assembly.

WARNING

Whilst every effort has been made in the manufacture of this awning to remove any sharp edges you should handle all components with care and wear gloves to avoid accidental injury during assembly of the framework.

Please read all instruction thoroughly before proceeding and locate a level area in which to set up the awning.



1.

WIND OUT THE ROOF SHEET

STEP 1

Unlock the cassette by removing the hand wheel (if fitted). keep this safe as you will need to use it for the torsion bar fitting.

STEP 2

Place winding handle hook into eye of the gearbox.

STEP 3

Start to unwind the roof section, whenever possible have another person to support the fascia whilst being wound out.

STEP 4

Carry on winding until the arm hinge stops moving, this is as far as the roof sheet needs extending.

STEP 5

If the roof sheet goes slack, re-tension by winding the awning back in slightly.



2.

FIT THE CORNER POSTS

STANDARD TELESCOPIC POSTS (TUBE)

Located on a small hole at each corner of the fascia and secured with an R Pin. Once fitted adjust to a manageable height by the centre clamp.

HEAVY DUTY POSTS (SQUARE)

Located on a small hole at each corner of the fascia and secured with an R Pin. They can be adjusted at the bottom with the M10 hand wheel if necessary. If there is a base frame supplied with awning then the corner posts will be handed, with the base frame locator pins to the outside.



3. FIT THE SIDE ROOF RAILS

STEP 1

Slide up the PVC insert rod. This is located in the small pocket at the edge of the roof sheet. Push this up the pocket. This has now formed a beaded edge on the roof.

STEP 2

Take side awning rail section, these are square section aluminium bars with a flange either side, they are not handed. These can be supplied joined for storage purposes, make sure they are solid when fitting.

STEP 3

Feed these up the beaded edge on the roof sheet. They must slide on, so that the lower flange goes up the edge of the roof sheet and the upper flange can then be accessed for the side sheet.



ROOF SHEET

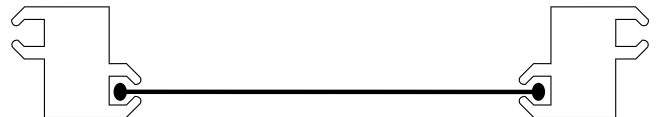

Slide side awning rails onto roof sheet with lower flange towards the roof.

At the top and bottom of the rail you will notice a V. Block, this locates onto the cassette box and front fascia.

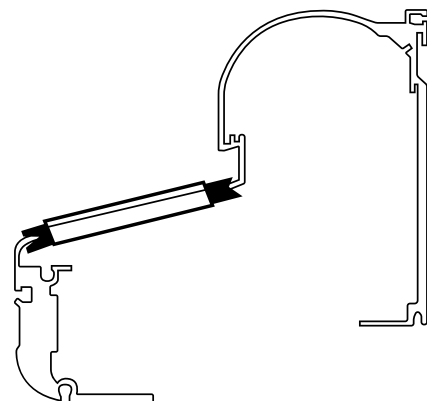

4. FIT THE TORSION BAR(S)

STEP 1

The torsion bar(s) is a round tube with cast alloy inserts at both ends. It can be supplied in one solid bar or joined for storage purposes.

STEP 2

Using the hand wheel fit the bar at the vehicle end first, this is the pole end that is bent.



STEP 3

Now secure at the fascia end with hand wheel, the bar is at a tight angle when doing this so you will need to slide it into position from the left hand side over the fascia bracket and fasten.



5. TENSION THE ROOF

Start to rewind the roof, this will create tension on the roof sheet and will lock the side roof rails and torsion bar(s) into place. **Take note:** when winding on tension, the roof should be feeding onto the bottom of the roller and not winding over the top.



6. SECURE THE AWNING DOWN

Before proceeding any further, secure the awning down at the corner post bases with the heavy duty pegs provided. In case of bad weather we recommend the use of guy ropes.



7. FITTING THE SHEETS

FRONT SHEET

Slide into the bottom groove in the fascia.

SIDE SHEETS

The sheets can now be put into place by first sliding them up the side roof rails and then down the tracking on the vehicle. (It may be useful to undo the zip nearest the vehicle making it easier to slide the side down the tracking).

STANDARD CORNER POSTS (TUBE)

Zip up the corners and adjust the sheets to the correct height before pegging out.

HEAVY DUTY CORNER POSTS (SQUARE)

To make fitting easier undo the zip, this zipped flap will allow the keder to be fed down the corner post easily, once in place zip back up.

VEHICLE SKIRT - optional

Slide the skirt keder into the tracking profile, at each end of the skirt is Velcro that attaches to the side sheet to seal the awning. Once fitted peg down.



8. TERRACE SHEETS AND RAIL - OPTIONAL

STANDARD TELESCOPIC POSTS

The terrace rail located on the front sheet will have a zip out section that once undone will allow the sheet to hang over the rail.

HEAVY DUTY POSTS

Feed the top terrace sheet into the fascia, once in place feed the terrace rail into the removable (velcroed) keder strip attached to the bottom of this panel. Now fit the rail into the keyway on each post and push into place. Fit the bottom terrace sheet by sliding the top keder into the terrace rail then down the legs (the corner post is routed out to enable this).



9. BASEFRAME - OPTIONAL WITH HEAVY DUTY POSTS

The front pole(s) are finished with an eyelet on both ends. Side poles are finished with an eyelet on one end and plain tube at the other.

To fit the base frame slide the poles into the pocket behind the mudwall.

Locate onto the steel bracket fitted on the foot and secured with an R clip.

Locate the two heavy duty hexagonal bases under the vehicle. Tighten up the side poles using the allen key provided.

Once the base frame is fitted the sheets can be tensioned down and locked in place with the small M8 hand wheel on the locator brackets.



10. DISMANTLING

STEP 1

Remove the base frame.

STEP 2

Remove the sheeting – **take note** if wet then leave out to dry as soon as possible. Sheets stored in a damp and dark condition can cause mildew.

STEP 3

Remove the side awning rails and torsion bar(s).

STEP 4

Pull the rods out of the roof pockets.

STEP 5

Remove the corner posts - support the fascia.

STEP 6

Retract the roof - see step 11.

STEP 7

Secure the fascia with the hand wheel (if fitted).



11. RETRACTING THE ROOF

Please note the following ‘troubleshooting’ points when winding the roof sheet in. Any of these could cause the fascia not to close properly. Ensure that you rewind the roof sheet in the correct direction – Under the roller. Check that the roof sheet pockets have not folded over – this can cause the fascia not to close on one side. Check that the roof sheet has not creased – this also can cause the fascia not to close correctly.

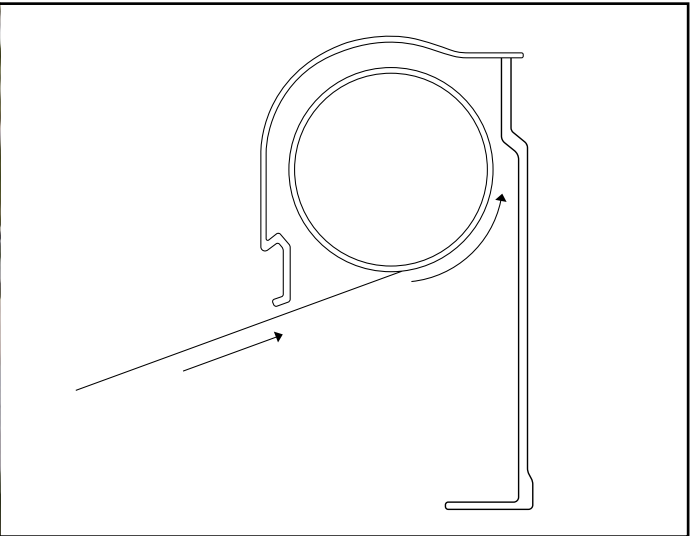

THE AWNING CO

 **MADE IN BRITAIN**

For further instructions
and advice **contact our
friendly team**

**The Awning Company Uk Limited
Unit 1, Jubilee Works, Vale Street
Bolton BL2 6QF**

Tel. +44 (0)1204 544900

Fax +44 (0)1204 544901

sales@theawningcompany.co.uk

www.theawningcompany.co.uk